

Homework #9

Question 1. For this Turing machine:

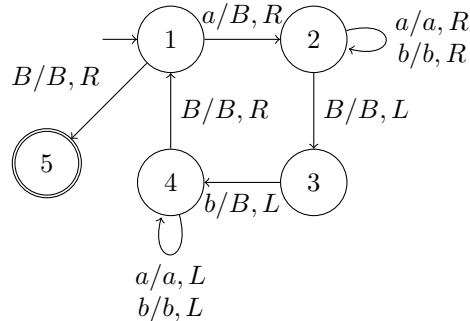

Write sequences of IDs showing that $aabb$ is accepted, and abb is rejected. What is the language of this Turing machine?

Question 2. For each of these languages, make a Turing machine:

- a) $\{bbx \mid x \in \{a, b\}^*\}$
- b) $\{xbb \mid x \in \{a, b\}^*\}$
- c) $\{x \in \{a, b\}^* \mid |x| < 3\}$
- d) $\{a^n b^k \mid k \geq n\}$

Question 3. There is a simple procedure to convert a DFA to a Turing machine. Describe in words how to do this conversion, and demonstrate your method by converting this DFA into a Turing machine:

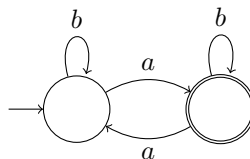

(Hint: your machine should never modify the tape, and always move to the right.)

Leftover questions about derivatives

Question 4. Show that this language is nonregular: $L = \{a^n cb^n c\}$.

Question 5. Show that this language is nonregular: $L = \{(bab)^n b^n\}$.

Question 6. For the language $L = \{xax^R \mid x \in \Sigma^*\}$:

- a) Show that L is regular when $\Sigma = \{a\}$.
- b) Show that L is nonregular when Σ has more than 1 element.